

## K135 Screed Rail Specifications

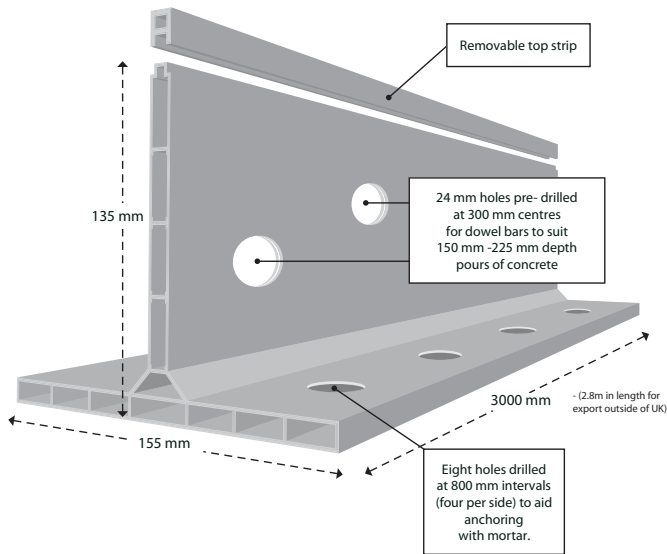

- Designed for pours of 150 mm-225 mm thick concrete
- Enables adjoining bays to be poured consecutively
- Pre-drilled holes in base for anchoring with mortar
- Pre-drilled holes in vertical face for locating dowel bars
- The profile is made in UPVC and has a built in expansion joint
- Once concrete is poured, K-FORM is left in place; no need to remove and clean
- Separate wear strip can be removed once concrete is set to allow joint sealing

## Top Strip Angle Joint Specifications

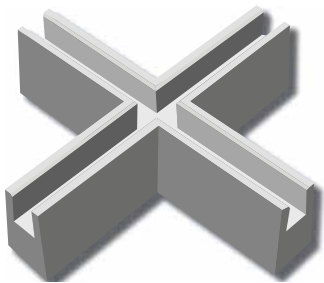

- ✓ Easily cut with a hand saw
- ✓ Made from the same resilient materials as the existing K-FORM top strip
- ✓ Suitable for use with bunion rollers, twin beams and most forms of mechanical concrete levelling and placing equipment

Top Strip Angle Joints intergrate seamlessly with K-FORM Screed Rails. They provide a clean and tidy joint detail at intersections and should be used when it is intended to leave the topstrip in place after pouring. Our new Top Strip Angle Joints integrate seamlessly with both our K85 and K135 screed rails.

[www.kform.co.uk](http://www.kform.co.uk)

## 25mm Extension Strip

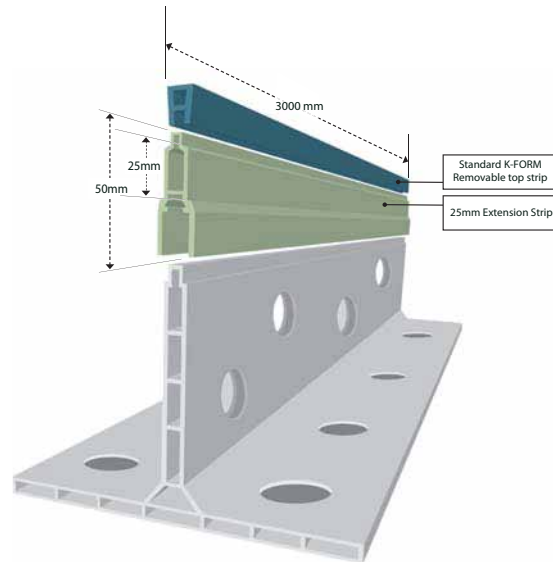

- Each extension strip enables K FORM Screed Rails to increase height by 25mm.
- Integrates seamlessly with K FORM Screed rails.
- Accepts the existing top strip to ensure K FORM wear resistance.
- Fast easy clip on design, no special tools or material needed.



Fender Steel  
20 Midland Road, Scunthorpe  
North Lincolnshire DN16 1DQ  
Tel: 01724 840609  
Fax: 01724 281902

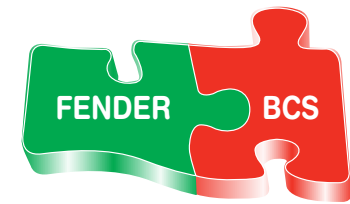

THE FENDER BCS GROUP OF COMPANIES

[www.fenderbcs.co.uk](http://www.fenderbcs.co.uk)

*"K-FORM Screed Rail is out of this world! It's so easy to put down, it does two jobs at once, and we could not get the work done as fast as we do, without K-FORM. I don't know of any other concrete form out there that does what K-FORM does."*

Alan Bullen - Commercial Developer  
A.B. Developments, Cambridgeshire

Using K-FORM  
will save you  
30% in Labour  
savings



[www.kform.co.uk](http://www.kform.co.uk)

[www.kform.co.uk](http://www.kform.co.uk)

## Why Choose K-FORM?

The K-FORM Screenshot Rail is a high quality product designed to save you time and money whatever the size of your contract.

The pouring of floor slabs have never been so easy. The simple light weight system can be set up four times quicker than traditional steel shutters.

With a built in expansion joint, click together design and removable top strip, K-FORM's patented design gives the best possible performance with quality results, finishing your project to complete satisfaction.

## Benefits Of Using K-FORM:

- Saves time and money
- No specialist tools required
- Lightweight - over 80% lighter than steel shuttering
- One person can install
- Reduces labour costs
- Increases pouring
- Completes the project quicker
- No removal afterwards
- No cleaning
- Non-metallic
- Fuel and Oil resistant
- Integral expansion joint
- 'Click-together' ease
- Safe to use when concreting petrol forecourts
- Pre-drilled holes for dowel bars
- Manufactured in durable UPVC
- Never rots or rusts
- No anchoring with metal stakes
- Available in 3 metre rails - 2.8m in length for export outside of UK
- Simple to use
- Pour more concrete per week
- Removable top strip
- Easy to seal concrete sections
- Non-conductive
- No diamond cutting
- Can be used with twin beams, roller screeds & vibro strikes
- No puncturing of DPM
- Made from recycled materials

K-FORM stays in place when the job is done



Cross Section of K-FORM.

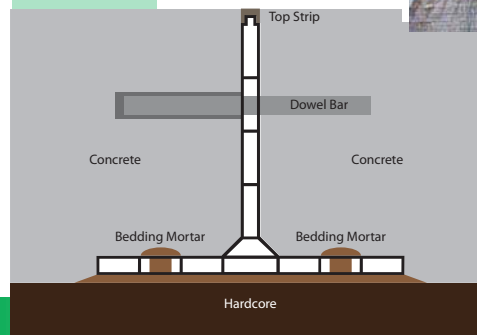

## How K-FORM Works:



K-FORM is ideal for concrete slabs of various thicknesses. The rail is simply laid on a lean mix or mortar bed to the required finished height.

1. Set up your string line
2. Cut the first top strip in half, attach to the first rail and fit joint clips.
3. Place spots of bedding mortar on the sub-base at intervals of 800mm to correspond with holes in the base
4. Place the rail on the bed and gently tap down with a rubber mallet until the top of the wear strip is at the desired level
5. Place bedding for next rail as in step 3
6. Join the second rail to the first with the joint clips
7. Fit the full length of the top strip across rails
8. Tap down the rail as in step 4
9. Each 3m K-FORM rail has pre drilled 24mm holes for dowel bars
10. Once the bedding mortar has cured you can start pouring concrete
11. K-FORM rails stay in place, therefore adjoining bays can be poured one after the other
12. Once the concrete has cured, the top strip can either be left in place or removed. The gap can subsequently be filled with a joint sealant



With K-FORM's removable top strip there is no need to diamond cut joints for sealant.



With K-FORM you can pour more concrete: Just set out your shuttering and pour bay after bay.



K-FORM's patented design allows concrete to set without any need to use additional expansion joints.

## K35 Screenshot Rail Specifications

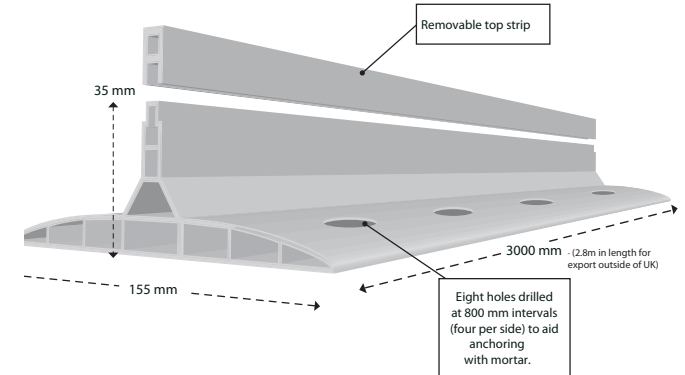

- Designed for pours of 50mm - 100mm thick concrete or screed
- Enables adjoining bays to be poured consecutively
- Pre-drilled holes in base for anchoring with mortar
- Fixing to steel deck possible with screws or shot nails
- The profile is made in UPVC and has a built in expansion joint
- Once concrete is poured, K-FORM is left in place; no need to remove and clean
- Separate wear strip can be removed once concrete is set to allow joint sealing

## K85 Screenshot Rail Specifications

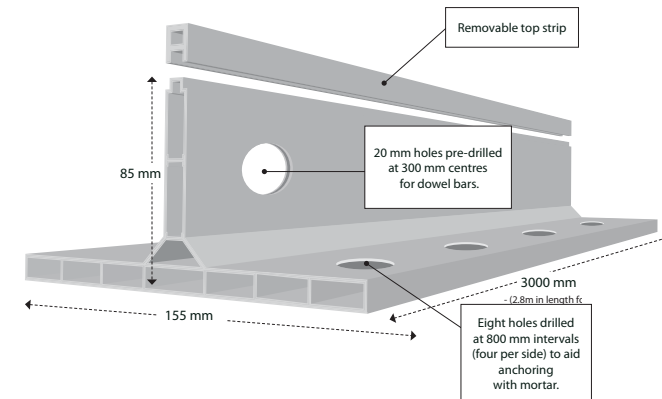

- Designed for pours of 100 mm - 140 mm thick concrete
- Enables adjoining bays to be poured consecutively
- Pre-drilled holes in base for anchoring with mortar
- Pre-drilled holes in vertical face for locating dowel bars
- The profile is made in UPVC and has a built in expansion joint
- Once concrete is poured, K-FORM is left in place; no need to remove and clean
- Separate wear strip can be removed once concrete is set to allow joint sealing